

ULA

Planning and Assembly Installation Manual 304



Installer responsibility

The installer is solely responsible for:

- Complying with all local or national building codes, including any that may supercede this manual.
- Ensuring that UNIRAC and other products are appropriate for the particular installations and installation environment.
- Ensuring safe installation of all electrical aspects of the PV array.



UNIRAC welcomes input concerning the accuracy and user-friendliness of this publication.

Figure 1. U-LA components

Components and quantities specific to your installations are listed on your quotation.

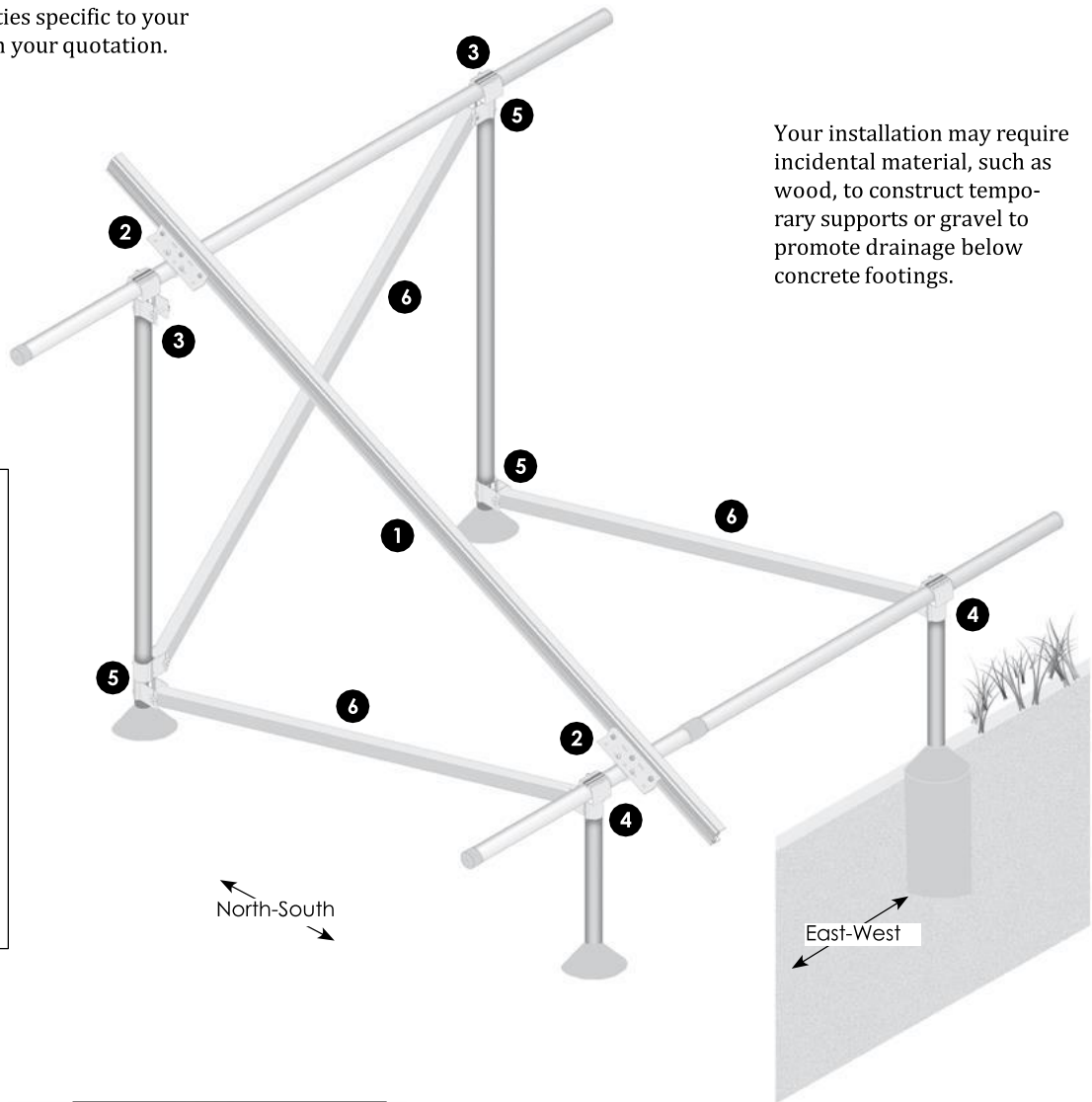



 Stainless steel hardware can seize up, a process called galling. To significantly reduce its likelihood, (1) apply lubricant to bolts, preferably an anti-seize lubricant, available at auto parts stores, (2) shade hardware prior to installation, and (3) avoid spinning on nuts at high speed.

1. SOLARMOUNT rail— Standard or HD (heavy duty) rails support PV modules.

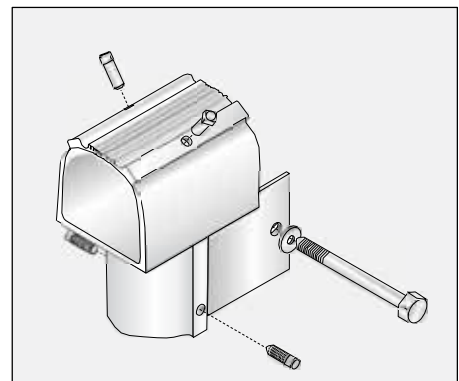
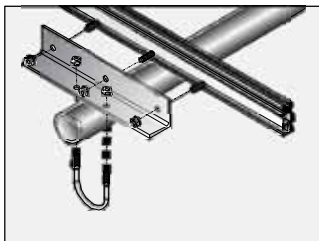

3. Rear cap—Attaches back horizontal pipe to vertical pipes. Includes $\frac{3}{8}$ -inch hardware: 2 U-bolts sized for pipe and 4 flange nuts, and 2 or 4 set screws.

2. Rail bracket—Attaches rail to horizontal pipes. Includes $\frac{3}{8}$ -inch hardware: 1 U-bolt, 3 hexhead bolts, and 5 flange nuts.



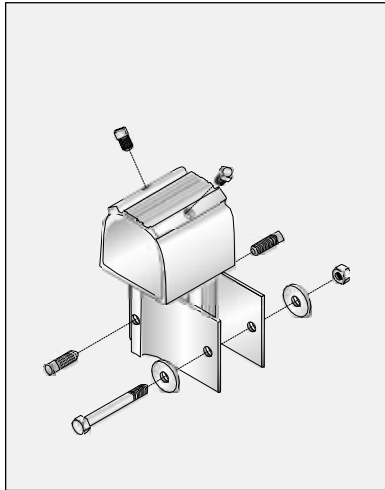

4. Front cap—Attaches front horizontal pipe to vertical pipes and anchors upper end of north-south braces. Includes $\frac{3}{8}$ -inch hardware: 2 U-bolts and cross-brace bolt sized for pipe, 5 flange nuts, and 2 or 4 set screws.

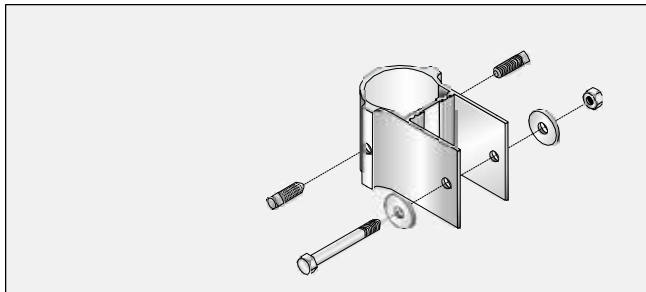

5. Slider—Attaches lower end of north-south cross braces to rear legs. Anchors both ends of east-west braces (if employed in your installation). Includes $\frac{3}{8}$ -inch hardware: 1 cross-brace bolt sized for pipe, 1 flange nut, and 2 or 4 set screws.



6. Cross Brace—Provides north-south and east-west diagonal bracing. Extrusion size matches other 2- or 3-inch components.

Be prepared to cut and drill braces on the jobsite. Hole location is 1" from the end of brace along the center line.

Material specifications

Rails, caps, sliders, rail brackets, cross braces, pro series end and mid clamps, and top mounting clamps—6105-T5 aluminum extrusion; caps are welded.

Fasteners—304 stainless steel.

Horizontal and vertical pipe (installer supplied)—Minimum

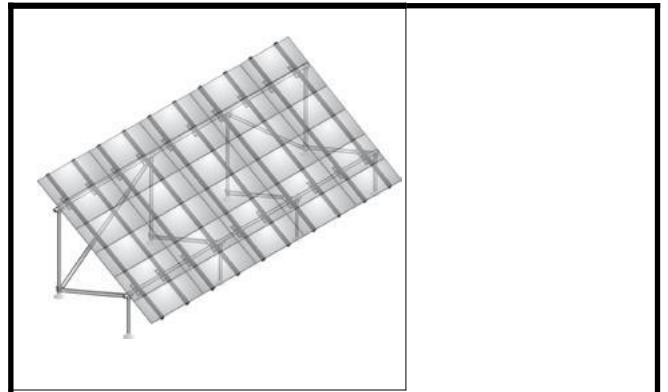

Figure 2: Module mounting systems

Top mounting End and Mid clamp and Pro Series End and Mid clamp—Mounts modules in landscape mode.

End Clamp

Legacy

Pro Series



Mid Clamp

Legacy

Pro Series



requirement of ASTM A53B Schedule 40 galvanized steel pipe in 2" or 3" diameter.

Concrete (installer supplied)—Rated for a minimum of 2,500 pounds per square inch.

Planning the array prior to installation

On a U-LA truss structure, leg caps, rail brackets, and cross pipe couplers must be offset from one another in the east-west direction. If you are using top mounting clamps, any conflicts among these components can be dealt with easily on site, so there is never the need to deviate from the average east/west leg spacing listed on your Specs Sheet. Go on to “Lay out and excavate leg positions,” below.

Make a scale drawing to identify potential component conflicts (see Fig. 3 or Fig. 4). If one occurs, use one or more of these solutions:

- Shift the position of conflicting pair of legs without exceeding maximum leg spacing listed on your Specs Sheet.
- Shift all cross pipes and rails relative to the legs without exceeding maximum cross pipe overhang listed on your Specs Sheet.

Cross pipe coupler conflicts and minor conflicts between leg caps and rail brackets, where offsets are near but not below the minimums listed in Figure 3 or 4, can be dealt with easily on site.

Figure 3. Planning installs with bot- tom mount- ing clips

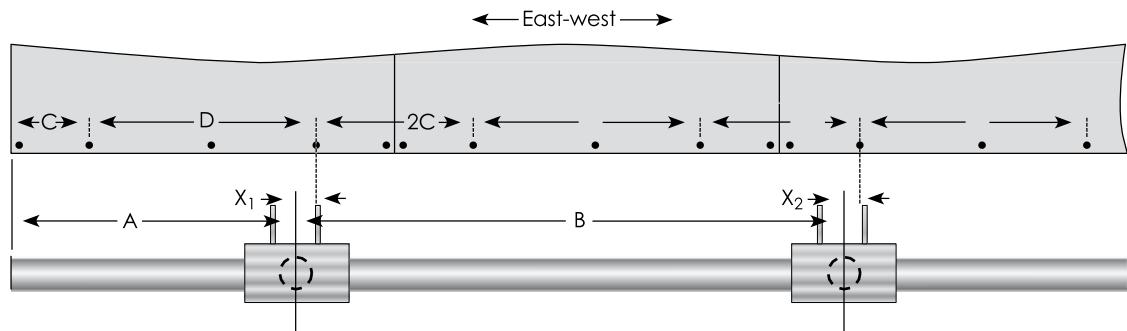

Create a dimensional drawing that lists overhang (A) and average leg spacing (B), which are listed under “Design Parameters” on page 2 of your Specs Sheet. Determine east-west offsets between vertical legs (dotted circles) to the module mounting holes you

intend to use. C and D depend on your specific modules. Determine your offsets (X_1 , X_2 , etc.). If the offsets are less than the applicable minimum offset below, you will need to slightly shift leg positions. Be sure to keep within maximum allowable spacing.

Lay out and excavate leg positions

Once the grid of leg positions has been established, verify that all angles are square.

Dig leg holes to the "Footing diameter" and "Footing depth" listed on page 2 of your Specs Sheet. If you need to promote drainage, go a few inches deeper and fill the difference with gravel.

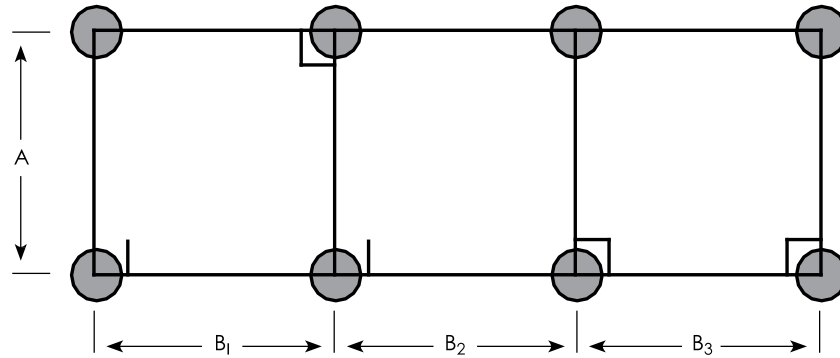

Figure 5. North-south leg spacing is fixed. East-west spacing (B_1 , B_2 , etc.) is identical in most installations; see "Average leg spacing e-w" (Nominal Values under "Design Parameters") on page 2 of your Specs Sheet. However, if you needed to shift leg positions, follow the east-west spacing you set during your planning session.

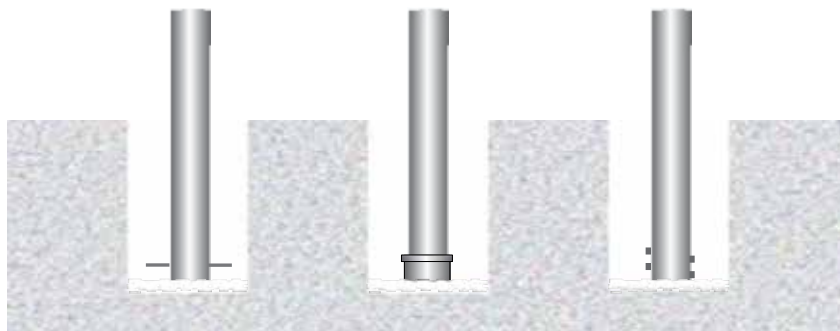

Figure 6. A length of rebar, a threaded cap, or bolts must be installed at the foot of the vertical pipes to prevent withdrawal of the footing.

Select an assembly sequence

The assembly sequence depends on installer preference and the size of the installation. Either of these options may be followed:

- If a U-LA has just a few pairs of legs, installers may prefer to assemble the full truss structure prior to pouring concrete. Figure 7 details this approach.
- On the larger U-LA structures with many pairs of legs, installers may prefer to place the vertical leg pipes, pour the concrete, and let it cure overnight before proceeding. Figure 8 details this approach.

In either case, when mounting rails be sure to center them on the horizontal pipes, which will leave about 20 percent overhang on north and south sides.

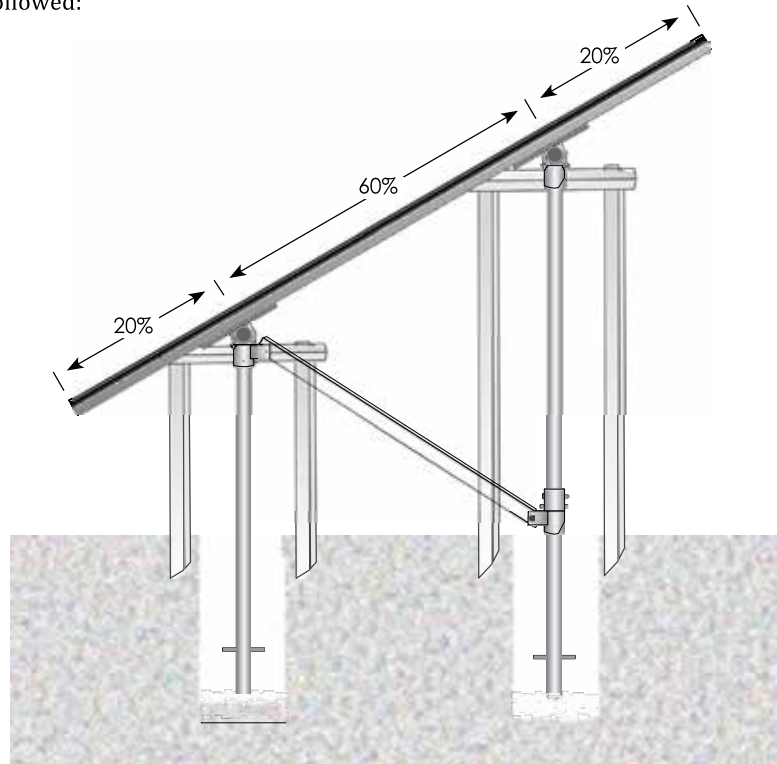

Figure 7. FULL-TRUSS OPTION. Footing holes should extend below the frost line. You may elect to use a few inches of gravel at the base of the holes to promote drainage. Loosely assemble the full truss structure, using wood supports to stabilize vertical and horizontal pipes. When cross braces and rails are in place, square up the array and tighten fasteners. Pour concrete after array is fully assembled, save for the modules themselves. See page 8 of this manual for installation notes.

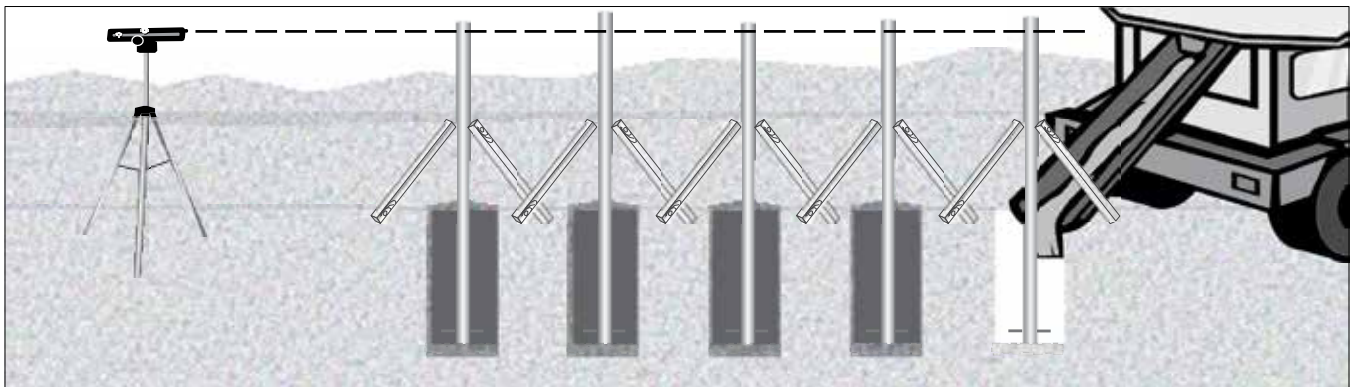

Figure 8. LEGS-FIRST OPTION. Footing holes should extend below the frost line. You may elect to use a few inches of gravel at the base of the holes to promote drainage. Using wood supports, level and square vertical leg pipes. Be certain that legs are precisely

aligned and that the front and back rows are parallel. Pour cement and allow to cure overnight before proceeding. Sighting with a laser level, transit, or string line, even the tops of the poles. See page 8 of this manual for installation notes.

Installation notes

Regardless of your assembly procedure, review these notes prior to installation and keep them handy for reference on site.

Shape concrete pillars for drainage

Slope concrete away from the legs to promote drainage. This can be done above ground or slightly below the surface. ***Be sure footings extend below the frost line.***

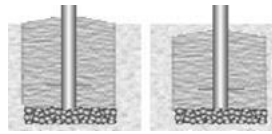

Figure 9. Drainage options.

Don't forget your sliders!

A forgotten or misplaced sliding truss anchor can result in extensive disassembly. To avoid this needless labor, be sure that all sliders are in place and correctly oriented.

Rail assembly options for landscape mode

All Unirac specified module mounting systems facilitate assembly of rails to the truss structure prior to mounting the PV modules.

Recommended torques for fasteners

- Set screws for leg caps and sliders: 15 foot-pounds.
- 3/8-inch serrated flange nuts for U-bolts and rail brackets: 8 foot-pounds.
- 1/4-inch module mounting hardware: 10 foot-pounds

Pipe coupler positions

Remember that cross pipe couplers need to be offset from both leg caps and rail brackets. As a general guideline, place pipe couplers one-quarter to one-third of the way between leg caps and roughly midway between rail brackets.

Minor conflicts between leg caps and rail brackets

Rail brackets, rails, and module mounts can go together in several ways. If a pair of rail brackets conflicts with leg cap positions, consult the table below. For top mounting clips, Figures 3 and 4 (pp. 4–5) illustrates the arrangements allowing the least offset between module mounting holes and leg pipe centers.

This racking system may be used to ground and/or mount a PV module complying with UL 1703 only when the specific module has been evaluated for grounding and/or mounting in compliance with the included instructions.

Solutions to minor conflicts between leg caps and rail brackets

Module mounting style	Solutions (employ one or more as needed)
Top mounting clamps (landscape)	Shift rail toward the end of the module, reversing (if necessary) rail bracket and rail and moving them to the other side of the leg cap.

*Rail brackets, rails, and module mounts can be configured in several ways. Figures 3 and 4 (pp. 4–5) illustrates the arrangement that permits the least offset between rail brackets and leg caps.

Microinverter Mounting



INSTALL MICROINVERTER MOUNT T-BOLT: Apply Anti-Seize and install pre-assembled 1/4" dia. bonding T-bolts into top 1/4" rail slot at microinverter locations. Rotate bolts into position.



INSTALL MICROINVERTER: Install microinverter on to rail. Engage with bolt.



INSTALL MICROINVERTER: TORQUE VALUE (See Note on PG. A)
1/4" nut to 10 ft-lbs w/Anti-Seize



ALIGN POSITION INDICATOR: Verify that position indicator on bolt is perpendicular to rail.

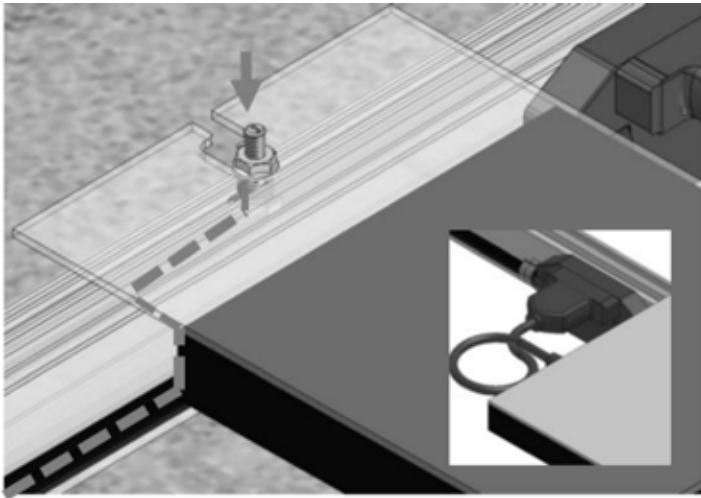

SM EQUIPMENT GROUNDING THROUGH ENPHASE MICROINVERTERS

The Enphase M215 and M250 microinverters have integrated grounding capabilities built in. In this case, the DC circuit is isolated from the AC circuit, and the AC equipment grounding conductor (EGC) is built into the Enphase Engage integrated grounding (IG) cabling.

In order to ground the SOLARMOUNT racking system through the Enphase microinverter and Engage cable assembly, there must be a minimum of three PV modules connected to the same trunk cable within a continuous row. Continuous row is defined as a grouping of modules installed and bonded per the requirements of this installation guide sharing the same two rails. The microinverters are bonded to the SOLARMOUNT rail via the mounting hardware. Complete equipment grounding is achieved through the Enphase Engage cabling with integrated grounding (IG). No additional EGC grounding cables are required, as all fault current is carried to ground through the Engage cable.

Standard System Grounding

WEEBLUG
Single Use Only



**TERMINAL TORQUE,
Install Conductor and
torque to the following:
6-14 AWG: 5ft-lbs**

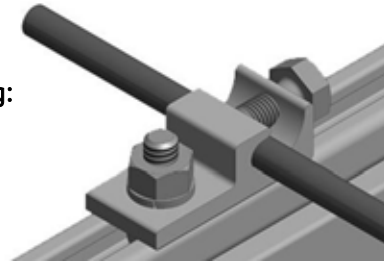

WEEBLUG CONDUCTOR - UNIRAC P/N 008002S:

Apply Anti Seize and insert a bolt in the aluminum rail and through the clearance hole in the stainless steel flat washer. Place the stainless steel flat washer on the bolt, oriented so the dimples will contact the aluminum rail. Place the lug portion on the bolt and stainless steel flat washer. Install stainless steel flat washer, lock washer and nut. Tighten the nut until the dimples are completely embedded into the rail and lug.

ONLY ONE LUG PER ROW OF MODULES:

Only one lug per row of modules is required. See Page F for additional lugs required for expansion joint

TORQUE VALUE 10 ft lbs. (See Note on PG. A)

See product data sheet for more details, Model No. WEEB-LUG-6.7

GROUNDING LUG MOUNTING DETAILS:

Details are provided for both the WEEB and IlSCO products. The WEEBLug has a grounding symbol located on the lug assembly. The IlSCO lug has a green colored set screw for grounding indication purposes. Installation must be in accordance with NFPA NEC 70, however the electrical designer of record should refer to the latest revision of NEC for actual grounding conductor cable size.

Required if not using approved integrated grounding microinverters

GROUNDING LUG - BOLT SIZE & DRILL SIZE		
GROUND LUG	BOLT SIZE	DRILL SIZE
WEEBLug	1/4"	N/A - Place in Top SM Rail Slot
ILSCO Lug	#10-32	7/32"

- Torque value depends on conductor size.
- See product data sheet for torque value.

**Star Washer is
Single Use Only**



**TERMINAL TORQUE,
Install Conductor and
torque to the following:
4-6 AWG: 35in-lbs
8 AWG: 25 in-lbs
10-14 AWG: 20 in-lbs**

ILSCO LAY-IN LUG CONDUCTOR - UNIRAC P/N 008009P: Alternate Grounding Lug - Drill, deburr hole and bolt thru both rail walls per table.

TORQUE VALUE 5 ft lbs. (See Note on PG. A)

See ILSCO product data sheet for more details, Model No. GBL-4DBT.

GROUNDING NOTES

The installation must be conducted in accordance with the National Electric Code (NEC) and the authority having jurisdiction. Please refer to these resources in your location for required grounding lug quantities specific to your project.

ELECTRICAL CONSIDERATIONS

ULA is intended to be used with PV modules that have a system voltage less than or equal to that allowable by NEC. For standard system grounding a minimum 10AWG, 105°C copper grounding conductor should be used to ground a system, according to the National Electric Code (NEC). It is the installer's responsibility to check local codes, which may vary.

Pro Series: Endclamp, First Module & Trim

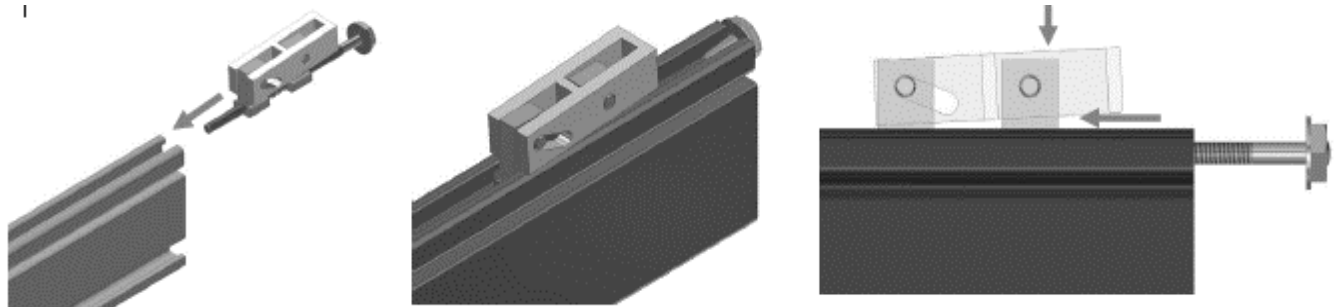

INSTALL END CLAMPS ON RAIL:
Slide end clamp on to rail by engaging the two t-guide brackets with the top slot of the rails. **Ensure bolt is extended as far as possible so that clamp is positioned at max. distance from end of rail.**

POSITION END CLAMPS:
Slide end clamp assembly on to rail until bolt head engages with end of rail. **End clamps are positioned on rails prior to the first end module and prior to the last end module.**

NOTE: To assist insertion of clamp into rail slot, Pressure may be applied to top or side of bracket as shown. **Do not force clamp into rail by pushing on bolt with excessive force.**

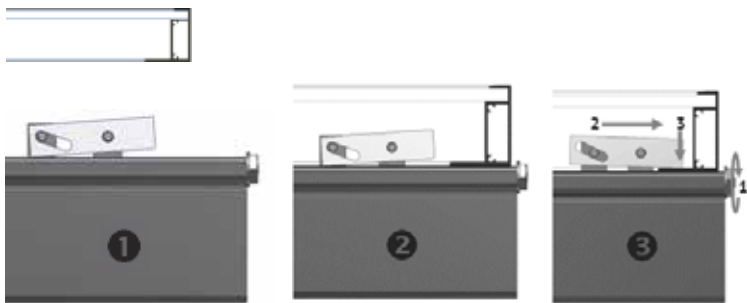

INSTALL FIRST MODULE: Install the first end module onto rails with the flange of the module frame positioned between end clamps at ends of rails.

ENGAGE CLAMP: While holding module in position and with flange in full contact with rail, rotate end clamp bolt until clamp engages with flange to provide clamp force. **To ensure bolt is not over-torqued, use low torque setting on drill or if using an impact driver, stop rotation as soon as impact action of driver begins.**
TORQUE VALUE (See table and notes on PG. 1)
End clamp bolt to 3 ft-lbs, No anti-seize

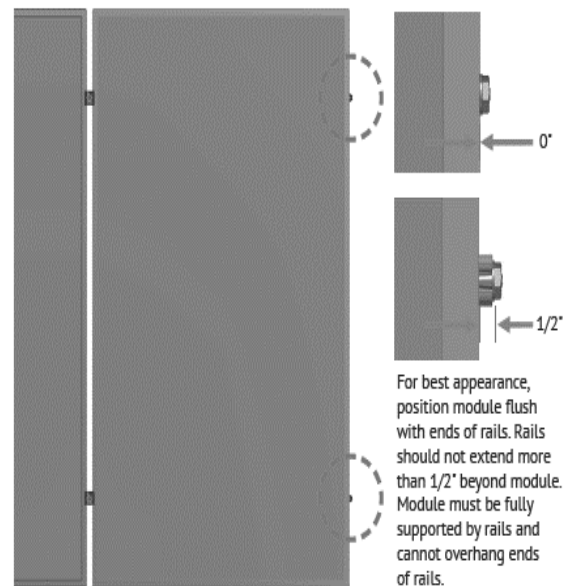

For best appearance, position module flush with ends of rails. Rails should not extend more than 1/2" beyond module. Module must be fully supported by rails and cannot overhang ends of rails.

Legacy: Endclamp, First Module & Trim

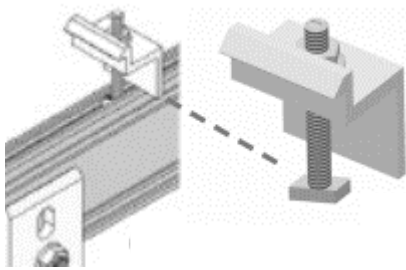

INSTALL MODULE ENDCLAMPS:
The Endclamp is supplied as an assembly with a T-bolt, serrated flange nut, and washer. The washer retains the clamp at the top of the assembly. This will enable the clamp to remain upright for module installation.

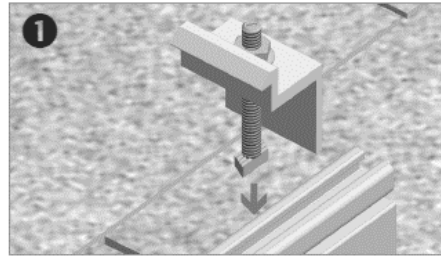

INSERT ENDCLAMP T-BOLT: Insert 1/4" T-bolt into rail.

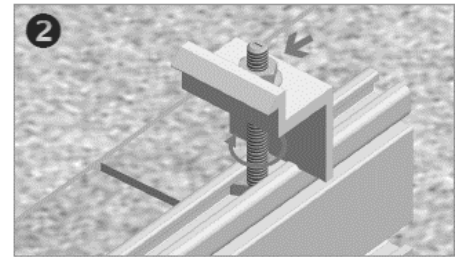

ROTATE ENDCLAMP T-BOLT: Rotate T-bolt into position. Verify that the position indicator & T-bolt shaft are angled in the correct position.

End clamps are positioned on rails prior to the first end module and installed after the last end module.

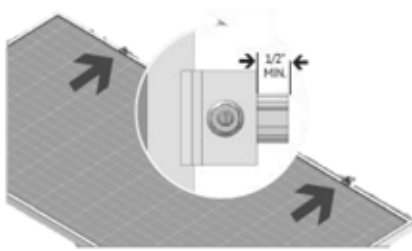

INSTALL FIRST MODULE: Install the first end module onto rails. Engage module frame with Endclamps. Verify that the position indicator & T-bolt shaft are angled in the correct position.

TORQUE VALUE (See Note on PG. A) 1/4" nuts to 10 ft-lbs. w/Anti Seize

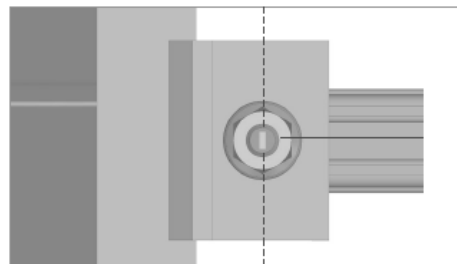

POSITION INDICATOR - SERRATED T-BOLT: Verify the T-bolt position indicator is perpendicular to the rail.

TRIM INSTALLATION INSTRUCTIONS

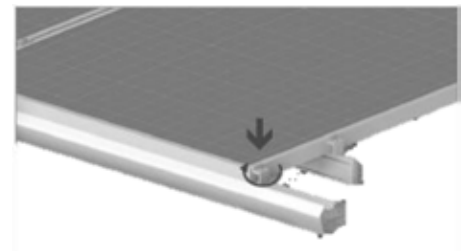

TRIM ENDCLAMPS: Install Endclamps on Trim in like manner to module endclamps per install instructions above. **TORQUE VALUE (See Note on PG. 1) 1/4" nuts to 10 ft-lbs w/ Anti Seize**

Legacy: Bonding Midclamp & Trim

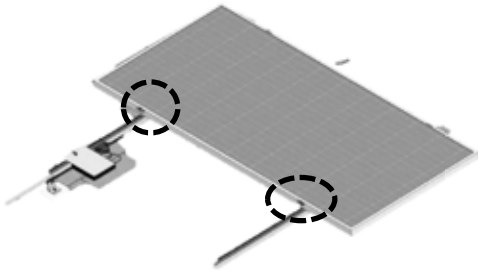

INSTALL MIDCLAMPS: Midclamp is supplied as an assembly with a T-bolt for module installation. Clamp assemblies may be positioned in rail near point of use prior to module placement.

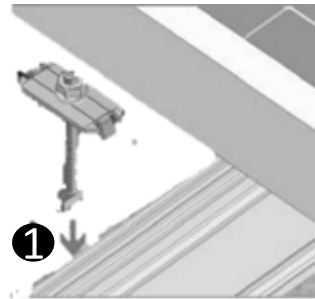

INSERT MIDCLAMP T-BOLT: Apply Anti-Seize and insert 1/4" T-bolt into rail.

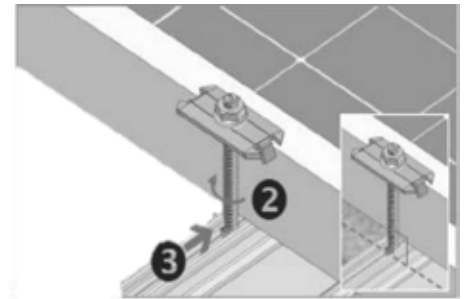

ROTATE MIDCLAMP T-BOLT: Rotate bolt into position and slide until bolt and clamp are against module frame. Do not tighten nut until next module is in position. Verify that the position indicator & T-bolt shaft are angled in the correct position.

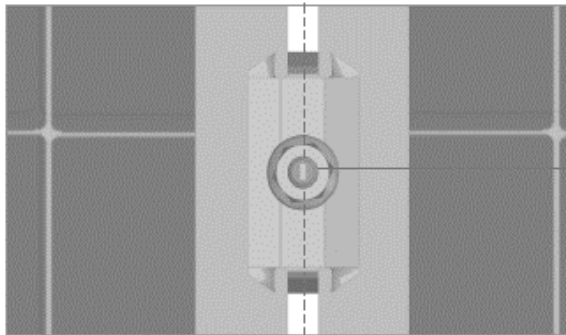

POSITION INDICATOR - SERRATED T-BOLT: Verify the T-bolt position indicator is perpendicular to the rail.

TRIM INSTALLATION INSTRUCTIONS

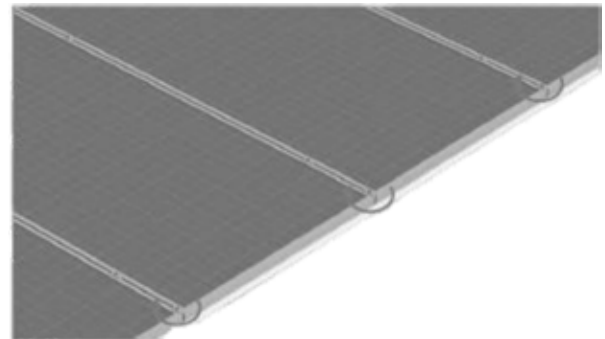

TRIM MIDCLAMPS: Ensure Trim lip is in contact with module face and verify alignment marks on T-bolts are in proper position, tighten midclamp on Trim, repeat at each gap between modules.

TORQUE VALUE (See Note on PG. 1)
1/4" nuts to 10 ft-lbs w/ Anti Seize

Pro Series: Bonding Midclamp & Trim

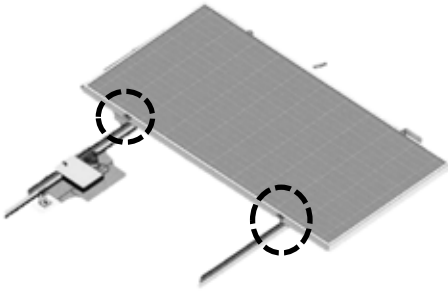

INSTALL MIDCLAMPS: Midclamp is supplied as an assembly with a T-bolt for module installation. Clamp assemblies may be positioned in rail near point of use prior to module placement.

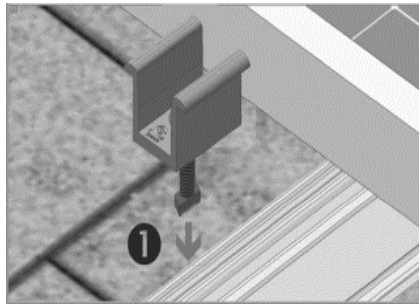

INSERT MIDCLAMP ASSEMBLY: Insert 1/4" T-Bolt into top slot of rail

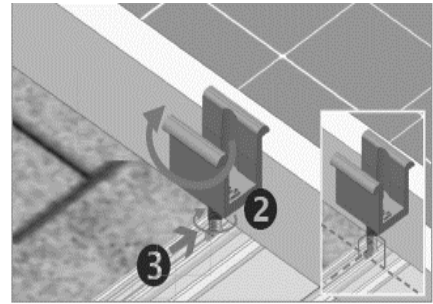

MIDCLAMP: Rotate midclamp assembly and slide until clamp is against module frame. Do not tighten nut until next module is in position. Ensure bolt is perpendicular to rail.

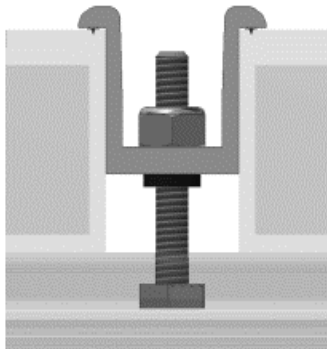

PLACE ADJACENT MODULE AGAINST CLAMPS:

Modules must be tight against clamps with no gaps. Tighten nut to required torque.

TORQUE VALUE (See table and notes on PG. A)

11 ft-lbs. No anti-seize.

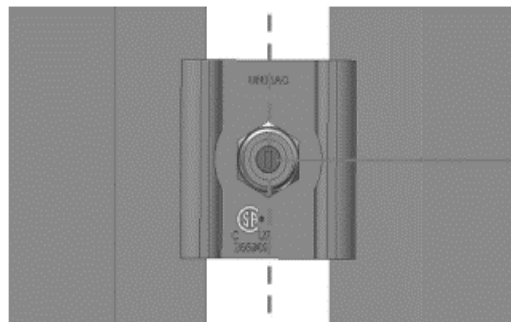

POSITION INDICATOR - SERRATED T-BOLT:

Verify the T-bolt position indicator is perpendicular to the rail.

Legacy: Remaining Modules

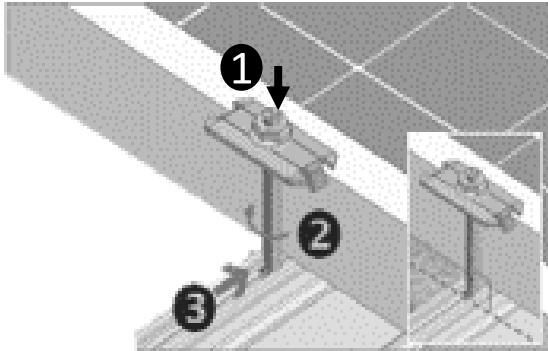

INSTALL REMAINING MID-CLAMPS: Proceed with module installation. Engage each module with previously positioned Midclamp assemblies.

NOTE: Apply Anti-Seize to each Mid Clamp prior to installation.

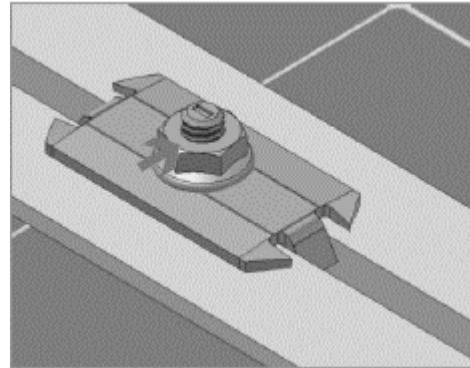

POSITION T-BOLT ALIGNMENT MARKS: Verify that the position indicator(s) & T-bolt shaft(s) are angled in the correct position.
TORQUE VALUE (See Note on PG. A)
 1/4" nuts to 10 ft-lbs. w/Anti Seize

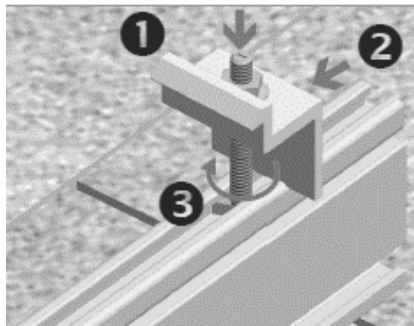

INSTALL ENDCLAMPS: Apply Anti-Seize and install final Endclamps in same manner as first Endclamps. Slide clamps against module.
TORQUE VALUE (See Note on PG. A)
 1/4" nuts to 10 ft-lbs. w/Anti Seize

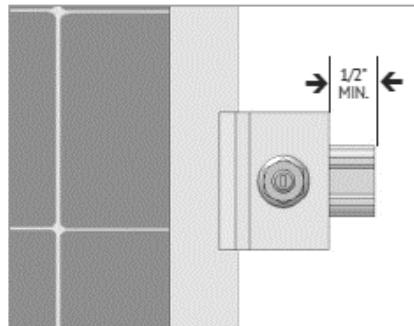

POSITION T-BOLT ALIGNMENT MARKS & CUT RAIL: Verify that the position indicator(s) & T-bolt shaft(s) are angled in the correct position. Trim off any excess rail, being careful not to cut into the roof. Allow 1/2" between the Endclamp and the end of the rail.

TRIM INSTALLATION INSTRUCTIONS

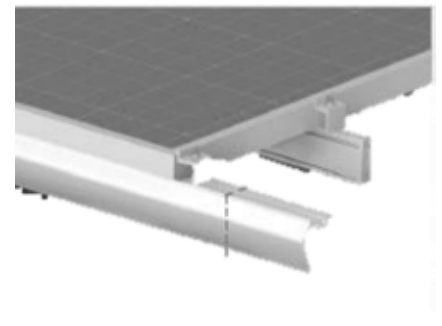

FINISH TRIM INSTALLATION, INSTALL ENDCLAMP & CUT EXCESS RAIL: Install final endclamp & Cut away excess Trim at end of array or where required for proper cantilevers. See **D&E Guide** or **U-Builder** for allowable cantilevers.
TORQUE VALUE (See Note on PG. 1)
 1/4" nuts to 10 ft-lbs w/ Anti Seize

Pro Series: Remaining Modules

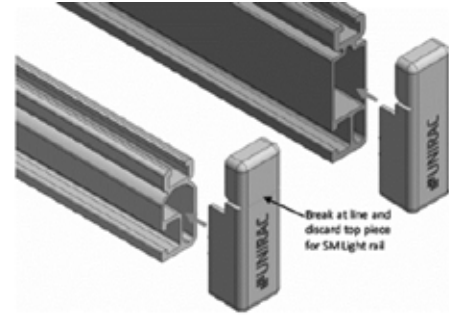
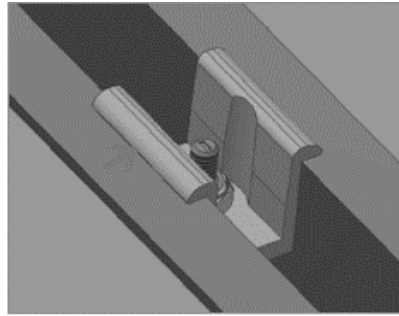
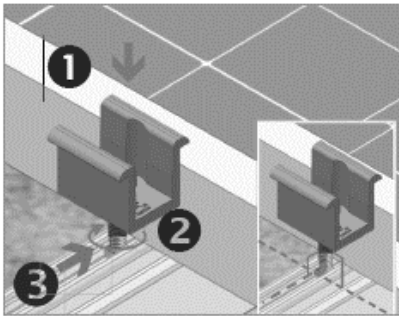

INSTALL REMAINING MID-CLAMPS:
 Proceed with module installation.
 Engage each module with previously positioned Midclamp assemblies.

POSITION T-BOLT ALIGNMENT MARKS:
 Verify that the position indicator(s) & T-bolt shaft(s) are angled in the correct position. Tighten to final torque.
TORQUE VALUE (See table and notes on PG. A) 11 ft-lbs. No anti-seize.

INSTALL END CAPS: End caps install as supplied on SM standard rail and SM light rail. If desired for SM light rail, the end cap may be modified as shown by hand, or by using a cutting tool.

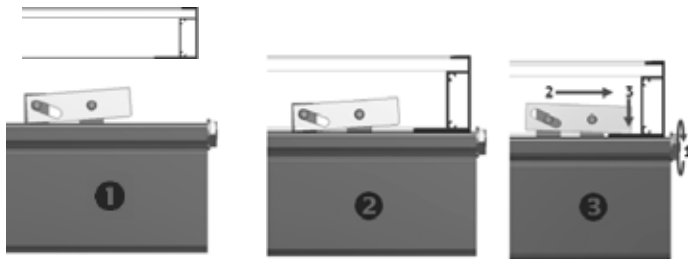

INSTALL FIRST MODULE: Install the first end module onto rails with the flange of the module frame positioned between end clamps at ends of rails.

ENGAGE CLAMP: While holding module in position and with flange in full contact with rail, rotate end clamp bolt until clamp engages with flange to provide clamp force.
To ensure bolt is not over-torqued, use low torque setting on drill or If using an impact driver, stop rotation as soon as impact action of driver begins.

TORQUE VALUE (See table and notes on PG. 1)
 End clamp bolt to 3 ft-lbs, No anti-seize

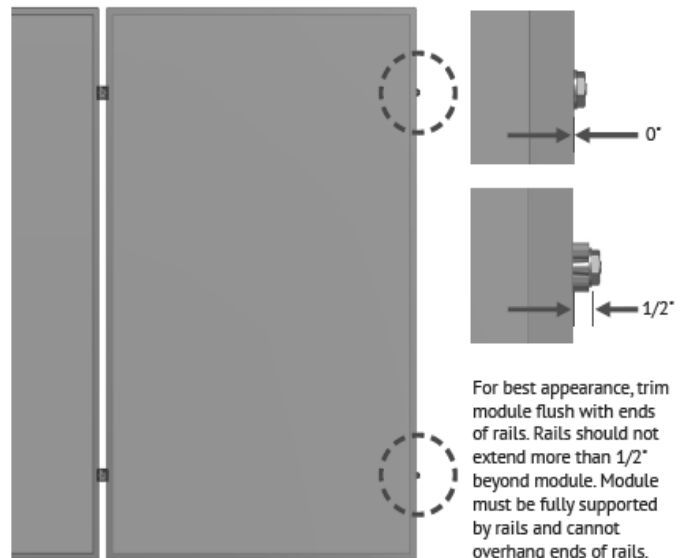

For best appearance, trim module flush with ends of rails. Rails should not extend more than 1/2" beyond module. Module must be fully supported by rails and cannot overhang ends of rails.

Pro Series: Bonding Connection Ground Paths

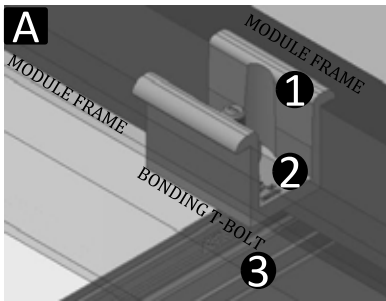

BONDING MIDCLAMP ASSEMBLY

- 1 Aluminum mid clamp with stainless steel bonding pins that pierce module frame anodization to bond module to module through clamp
- 2 Stainless steel nut bonds aluminum clamp to stainless steel T-bolt
- 3 Serrated T-bolt head penetrates rail anodization to bond T-bolt, nut, clamp, and modules to SM rail

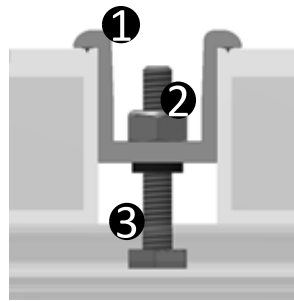

BONDING RAIL SPLICE BAR

- 1 Stainless steel self drilling screws drill and tap into splice bar and rail creating bond between splice bar and each rail section
- 2 Aluminum splice bar spans across rail gap to create rail to rail bond. Rail on at least one side of splice will be grounded.

Note: Splice bar and bolted connection are non-structural. The splice bar function is rail alignment and bonding.

Note:
Only one lug per module row required

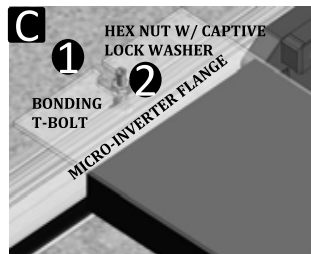
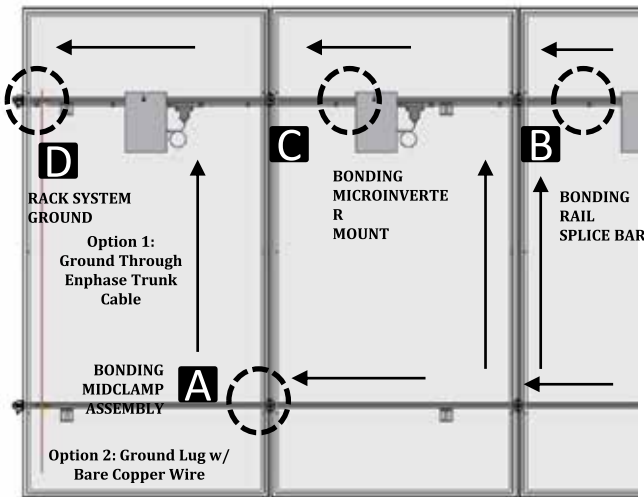

BONDING MICROINVERTER MOUNT

- 1 Hex nut with captive lock washer bonds metal microinverter flange to stainless steel T-bolt
- 2 Serrated T-bolt head penetrates rail anodization to bond T-bolt, nut, and L-foot to grounded SM rail

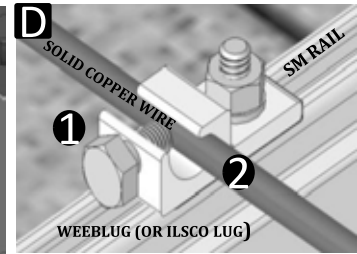

RACK SYSTEM GROUND

- 1 WEEB washer dimples pierce anodized rail to create bond between rail and lug
- 2 Solid copper wire connected to lug is routed to provide final system ground connection. **NOTE: IlSCO lug can also be used when secured to the side of the rail. See page I-3 for details**

GROUNDING NOTES

The installation must be conducted in accordance with the National Electric Code (NEC) and the authority having jurisdiction. Please refer to these resources in your location for required grounding lug quantities specific to your project.

ELECTRICAL CONSIDERATIONS

ULA is intended to be used with PV modules that have a system voltage less than or equal to that allowable by NEC. For standard system grounding a minimum 10AWG, 105°C copper grounding conductor should be used to ground a system, according to the National Electric Code (NEC). It is the installer’s responsibility to check local codes, which may vary.

Legacy: Bonding Connection Ground Paths

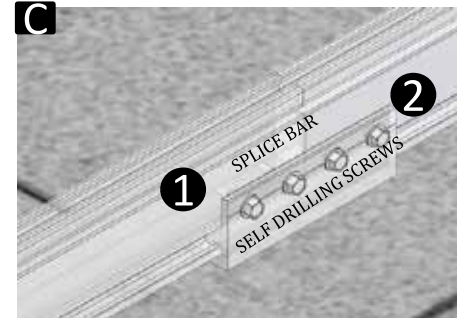
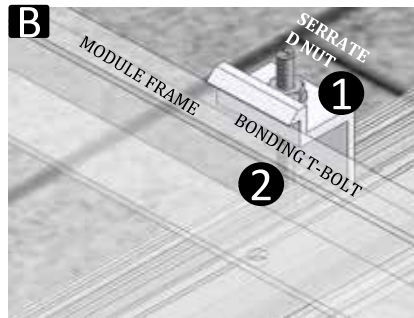
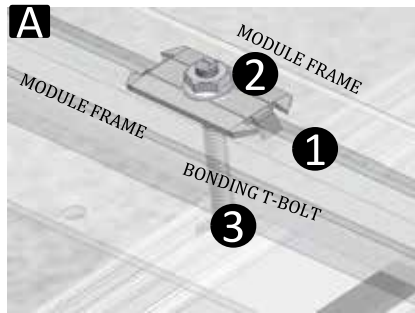

- 1** Stainless steel Midclamp points, 2 per module, pierce module frame anodization to bond module to module through clamp.
- 2** Serrated flange nut bonds stainless steel clamp to stainless steel T-bolt
- 3** Serrated T-bolt head penetrates rail anodization to bond T-bolt, nut, clamp, and modules to grounded SM rail.

- 1** Serrated flange nut bonds aluminum Endclamp to stainless steel T-bolt
- 2** Serrated T-bolt head penetrates rail anodization to bond T-bolt, nut, and Endclamp to grounded SM rail

- 1** Stainless steel self drilling screws drill and tap into splice bar and rail creating bond between splice bar and each rail section
- 2** Aluminum splice bar spans across rail gap to create rail to rail bond. Rail on at least one side of splice will be grounded.

Note: End clamp does not bond to module frame.

Note: Splice bar and bolted connection are non-structural. The splice bar function is rail alignment and bonding.

Note:
Only one lug per module row required

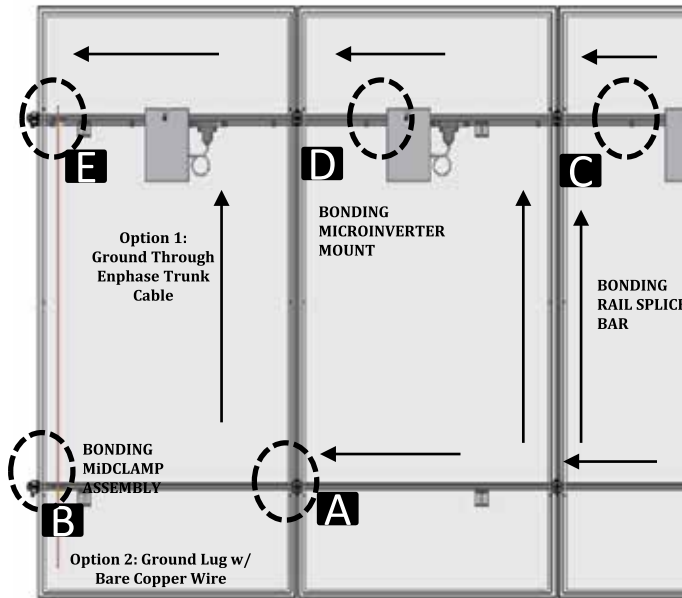

GROUNDING NOTES

The installation must be conducted in accordance with the National Electric Code (NEC) and the authority having jurisdiction. Please refer to these resources in your location for required grounding lug quantities specific to your project.

ELECTRICAL CONSIDERATIONS

ULA is intended to be used with PV modules that have a system voltage less than or equal to that allowable by NEC. For standard system grounding a minimum 10AWG, 105°C copper grounding conductor should be used to ground a system, according to the National Electric Code (NEC). It is the installer's responsibility to check local codes, which may vary.

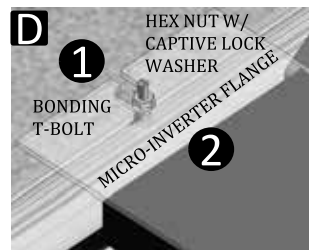

BONDING MICROINVERTER MOUNT

- 1** Hex nut with captive lock washer bonds metal microinverter flange to stainless steel T-bolt
 - 2** Serrated T-bolt head penetrates rail anodization to bond T-bolt, nut, and L-foot to grounded SM rail
- System ground including racking and modules may be achieved through the trunk cable of approved microinverter systems. See page I for details**

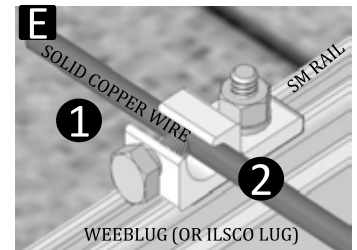

RACK SYSTEM GROUND

- 1** WEEB washer dimples pierce anodized rail to create bond between rail and lug
- 2** Solid copper wire connected to lug is routed to provide final system ground connection.

NOTE: IlSCO lug can also be used when secured to the side of the rail. See page I-3 for details

Appendix A

The SOLARMOUNT system has been certified and listed to the UL 2703 standard (Rack Mounting Systems and Clamping Devices for Flat-Plate Photovoltaic Modules and Panels). This standard included electrical grounding, electrical bonding, mechanical load and fire resistance testing.

In conducting these tests, specific modules are selected for their physical properties so that the certifications can be broadly applied. The following lists the specific modules that were tested and the applicability of those certifications to other modules that might come onto the market.

In addition to UL 2703 certification, Unirac performs internal testing beyond the requirements of certification tests in order to establish system functional limits, allowable loads, and factors of safety. These tests include functional system tests, and destructive load testing.

Mechanical Load Test Modules System Level Fire Classification			
<p>The modules selected for UL 2703 mechanical load testing were selected to represent the broadest range possible for modules on the market. The tests performed cover the following basic module parameters:</p> <ul style="list-style-type: none"> • Frame thicknesses greater than or equal to 1.0 mm • Basic single and double wall frame profiles (some complex frame profiles could require further analysis to determine applicability) • Clear and dark anodized aluminum frames • PV modules may have a reduced load rating, independent of the ULA load rating. Please consult the PV module manufacturer’s installation guide for more information 			
Tested Modules			
Module Manufacturer	Model/Series	Area [sqft]	UL2703 Certification Load Ratings
Hyundai	HiS-S325TI	21.06	Down – 113 PSF, Up – 50 PSF Down-Slope – 15 PSF
SunPower	SPR-P19-395-COM	22.20	Down – 113 PSF, Up – 50 PSF Down-Slope – 15 PSF
First Solar	FS-6xxx-P	27.12	Down – 33.9 PSF, Up – 33.9 PSF Down-Slope – 16.5 PSF

Manufacture	Module Model / Series
Aionrise	AION60G1, AION72G1
Aleo	P-Series & S-Series
Aptos Solar	DNA-120-MF10 DNA-120-(MF/BF)23 DNA-144-(MF/BF)23 DNA-120-(MF/BF)26 DNA-144-(MF/BF)26
Astronergy	CHSM6612 M, M/HV CHSM6612P Series CHSM6612P/HV Series CHSM72M-HC CHSM72M(DG)/F-BH
Auxin	AXN6M610T AXN6P610T AXN6M612T AXN6P612T
Axitec	AC-xxx(M/P)/60S, AC-xxx(M/P)/72S AC-xxxP/156-60S AC-xxxMH/120(S/V/SB/VB) AC-xxxMH/144(S/V/SB/VB)
Boviet	BVM6610, BVM6612
BYD	P6K & MHK-36 Series
Canadian Solar	CS1(H/K/U/Y)-MS CS3K-(MB/MB-AG/MS/P/P HE/PB-AG) CS3L-(MS/P) CS3N-MS CS3U-(MB/MB-AG/MS/P/P HE/PB/PB-AG) CS3W-(MS/P/P-PB-AG) CS5A-M CS6K-(M/MS/MS AllBlack/P/P HE) CS6P-(M/P) CS6U-(M/P/P HE) CS6X-P CSX-P ELPS CS6(A/P)-MM
Centrosolar America	C-Series & E-Series
CertainTeed	CT2xxMxx-01, CT2xxPxx-01, CTxxxMxx-01 CTxxxPxx-01, CTxxxMxx-02, CTxxxMxx-03 CTxxxMxx-04, CTxxxHC11-04
Eco Solargy	Orion 1000 & Apollo 1000
ET Solar	ET AC Module, ET Module
First Solar	FS-6XXX(A) FS-6XXX(A)-P, FS-6XXX(A)-P-I
Flextronics	FXS-xxxBB
FreeVolt	PVGraf

Manufacture	Module Model / Series
GCL	GCL-P6 & GCL-M6 Series
Hanwha SolarOne	HSL 60
Hansol	TD-AN3, TD-AN4 UB-AN1, UD-AN1
Heliene	36M, 36P 60M, 60P, 72M & 72P Series 144HC M6
HT Solar	HT72-156(M/P), HT72-156P-C, HT72-156P(V)-C HT72-156M(PDV)-BF, HT72-156M(PD)-BF HT60-156M-C, HT60-156M(V)-C
Hyundai	KG, MG, RW, TG, RI, RG, TI, KI, HI Series HiA-SxxxHG, HiD-SxxxRG(BK), HiS-S400PI
ITEK	iT-SE Series
Japan Solar	JPS-60 & JPS-72 Series
JA Solar	JAM72D30 xxx/MB, JAM78D10 xxx/MB JAP6 60-xxx JAM6(k)-60/xxx, JAP6(k)-72-xxx/4BB JAP72S##-xxx/** JAP6(k)-60-xxx/4BB, JAP60S##-xxx/** JAM6(k)-72-xxx/**, JAM72S##-xxx/** JAM6(k)-60-xxx/**, JAM60S##-xxx/** i. #: 01, 02, 03, 09, 10 ii. **: SC, PR, BP, HiT, IB, MW, MR ** = Backsheet, ## Cell technology
Jinko	JKM & JKMS Series JKMxxxM-72HL-V JKMxxxM-72HL4-(T)V JKMxxxM-7RL3-V
Kyocera	KD-F & KU Series
LA Solar	LSxxxHC(166)
LG Electronics	LGxxx(E1C/E1K/N1C/N1K/N2T/N2W/S1C/ S2W/Q1C/Q1K)-A5 LGxxx(A1C/M1C/M1K/N1C/N1K/Q1C/Q1K/ QAC/QAK)-A6 LGxxxN2W-B3 LGxxxN2T-B5 LGxxxN1K-B6 LGxxx(N1C/N1K/N2T/N2W)-E6 LGxxx(N1C/N1K/N2W/S1C/S2W)-G4 LGxxxN2T-J5 LGxxx(N1K/N1W/N2T/N2W)-L5 LGxxx(M1C/N1C/Q1C/Q1K)-N5 LGxxx(N1C/N1K/N2W/Q1C/Q1K)-V5 LGxxxN3K-V6

The modules selected for UL 2703 bonding and grounding testing represent the broadest possible range of modules on the market. The tests were performed for each specific bonding location using representative module frame profile sections. The tests performed cover the following basic module parameters:

- The frame profile must not have any feature that might interfere with the bonding devices that are integrated into the racking system
- Use with a maximum over current protection device OCPD of 30A
- Unless otherwise noted, all modules listed above include all wattages and specific models within that series
- Variable wattages are represented as “xxx”
- Items in parenthesis are those that may or may not be present in a compatible module’s model ID
- Slashes “/” between one or more items indicates that either of those items may be the one that is present in a module’s model ID

Manufacture	Module Model / Series
LONGi	LR4-60(HPB/HPH) LR4-72(HBD/HPH) LR6-60 LR6-60(BK/HPB/HPH/HV/PB/PE/PH) LR6-72 LR6-72(BK/HBD/HV/PB/PE/PH) RealBlack LR4-60HPB RealBlack LR6-60HPB
Meyer Burger	Meyer Burger Black, Meyer Burger White
Mission Solar Energy	MSE Mono, MSE Perc
Mitsubishi	MJE & MLE Series
Neo Solar Power Co.	D6M Series
Panasonic	VBHNxxxSA06/SA06B/SA11/SA11B VBHNxxxSA15/SA15B/SA16/SA16B, VBHNxxxKA, VBHNxxxKA03/04, VBHNxxxSA17/SA17G/SA17E/SA18/SA18E, VBHNxxxZA01/ZA02/ZA03/VBHNxxxZA04, EVPVxxx EVPVxxx(H/K/PK)
Peimar	SGxxxM (FB/BF) SMxxxM
Phono Solar	PSxxxM1-20/U PSxxxM1H-20/U PSxxxM1-20UH PSxxxM1H-20UH PSxxxM1-20/UH PSxxxM1H-20/UH PSxxxM-24/T PSxxxMH-24/T PSxxxM-24/TH PSxxxMH-24/TH
Prism Solar	P72 Series
Q.Cells	Plus, Pro, Peak, G3, G4, Peak G5(SC) , G6(+)(SC)(AC), G7, G8(+) Plus, Pro, Peak L-G2, L-G4, L-G5 Peak L-G5, L-G6, L-G7, L-G8(BFF) Q.PEAK DUO(BLK)-G6+ Q.PEAK DUO BLK-G6+/TS Q.PEAK DUO (BLK)-G7 Q.PEAK DUO L-(G7/G7.1/G7.2/G7.3/G7.7) Q.PEAK DUO (BLK) G8(+) Q.PEAK DUO L-(G8/G8.1/G8.2/G8.3) Q.PEAK DUO L-G8.3 BFG Q.PEAK DUO L-G8.3 BGT Q.PEAK DUO (BLK) ML-G9(+) Q.PEAK DUO XL-(G9/G9.2/G9.3) Q.PEAK DUO XL-G9.3 BFG

Manufacture	Module Model / Series
Q.Cells (cont.)	Q.PEAK DUO-G10+ Q.PEAK DUO BLK G10(+) Q.PEAK DUO BLK G10+ /AC Q.PEAK DUO (BLK) ML-G10(+) Q.PEAK DUO (BLK) ML-G10.a(+) Q.PEAK DUO XL-(G10/G10.2/G10.3/G10.c/ G10.d) Q.PEAK DUO XL-G10.3/BFG Q.PEAK DUO XL-G10.d/BFG Q.PEAK DUO XL-(G11.2/G11.3) Q.PEAK DUO XL-G11.3/BFG
REC	RECxxxAA (BLK/Pure) RECxxxNP (N-PEAK) RECxxxNP2 (Black) RECxxxPE, RECxxxPE72 RECxxxTP, RECxxxTP72 RECxxxTP2(M/BLK2) RECxxxTP2S(M)72
REC (cont.)	RECxxxTP3M (Black) RECxxxTP4 (Black)
Renesola	All 60-cell modules
Risen	RSM Series
S-Energy	SN72 & SN60 Series
SEG Solar	SEG-xxx-BMD-HV
Seraphim	SEG-(6PA/6PB/6MA/6MA-HV/6MB/E01/E11) SRP-(6QA/6QB) SRP-xxx-6MB-HV, SRP-320-375-BMB-HV, SRP-xxx-BMC-HV, SRP-390-450-BMA-HV, SRP-xxx-BMZ-HV, SRP-390-405-BMD-HV
Sharp	NU-SA & NU-SC Series
Silfab	SLA-M, SLA-P, SLG-M, SLG-P & BC Series SILxxx(BL/NL/NT/HL/ML/BK/NX/NU/HC)
Solaria	PowerXT-xxxR-(AC/PD/BD) PowerXT-xxxC-PD PowerXT-xxxR-PM (AC)
Solartech	STU HJT, STU PERC & Quantum PERC
SolarWorld	Sunmodule Protect, Sunmodule Plus/Pro
Suniva	MV Series & Optimus Series (35mm)
SunPower	AC, X-Series, E-Series & P-Series SPR E20 435 COM (G4 Frame) Axxx-BLK-G-AC, SPR-Mxxx-H-AC
SunTech	STP, STPXXXS - B60/Wnhb
Sun Edison	F-Series, R-Series
Talesun	TP572, TP596, TP654, TP660 TP672, Hipor M, Smart

The modules selected for UL 2703 bonding and grounding testing represent the broadest possible range of modules on the market. The tests were performed for each specific bonding location using representative module frame profile sections. The tests performed cover the following basic module parameters:

- The frame profile must not have any feature that might interfere with the bonding devices that are integrated into the racking system
- Use with a maximum over current protection device OCPD of 30A
- Unless otherwise noted, all modules listed above include all wattages and specific models within that series
- Variable wattages are represented as “xxx”
- Items in parenthesis are those that may or may not be present in a compatible module's model ID
- Slashes “/” between one or more items indicates that either of those items may be the one that is present in a module's model ID

Manufacture	Module Model / Series
Tesla	SC, SC B, SC B1, SC B2, TxxxS, TxxxH
Trina	PA05, PD05, DD05, DD06, DE06, DE09.05 PD14, PE14, DD14, DE14, DE15, DE15V(II) DEG15HC.20(II), DEG15MC.20(II) DEG15VC.20(II), DE18M(II), DEG18MC.20(II) DE19, DEG19C.20
TSMC	TS-150C2 CIGSw
Upsolar	UP-MxxxP, UP-MxxxM(-B)
URECO	D7Kxxx(H7A/H8A), D7Mxxx(H7A/H8A) FAKxxx(C8G/E8G), FAMxxxE7G-BB FAMxxxE8G(-BB), FBKxxxM8G
Vikram	Eldora, Somera, Ultima PREXOS VSMDHT.60.AAA.05 PREXOS VSMDHT.72.AAA.05
Vina	VNS-72M1-5-xxxW-1.5, VNS-72M3-5-xxxW-1.5, VNS-144M1-5-xxxW-1.5, VNS-144M3-5-xxxW-1.5, VNS-120M3-5-xxxW-1.0
VSUN	VSUN xxx-60M-BB, VSUNxxx-72MH VSUN 4xx-144BMH
Winaico	WST & WSP Series
Yingli	YGE & YLM Series
ZNShine Solar	ZXM6-72 Series ZXM6-NH144 ZXM6-NHLDD144

The modules selected for UL 2703 bonding and grounding testing represent the broadest possible range of modules on the market. The tests were performed for each specific bonding location using representative module frame profile sections. The tests performed cover the following basic module parameters:

- The frame profile must not have any feature that might interfere with the bonding devices that are integrated into the racking system
- Use with a maximum over current protection device OCPD of 30A
- Unless otherwise noted, all modules listed above include all wattages and specific models within that series
- Variable wattages are represented as “xxx”
- Items in parenthesis are those that may or may not be present in a compatible module’s model ID
- Slashes “/” between one or more items indicates that either of those items may be the one that is present in a module’s model ID

System Markings

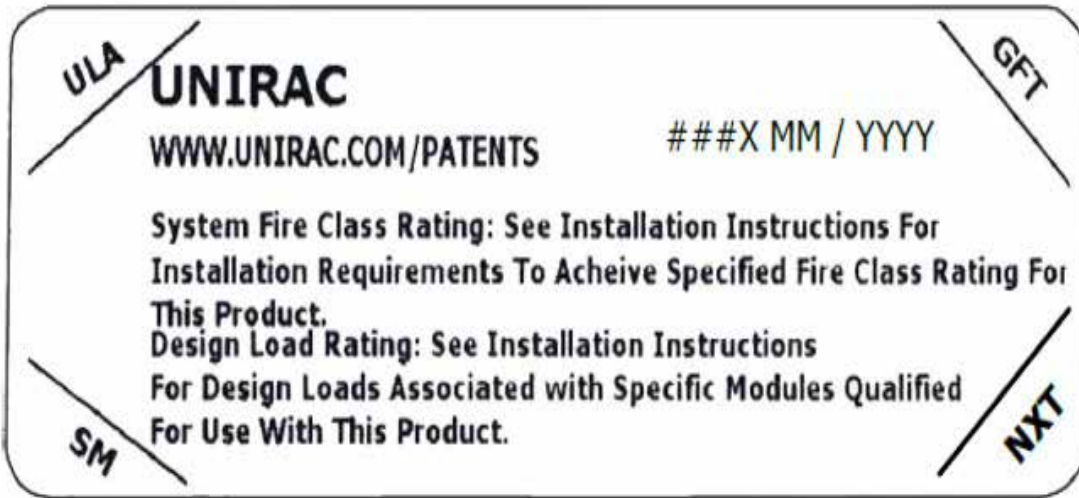

UL2703 CERTIFICATION MARKING LABEL Unirac ULA is listed to UL 2703. Marking Labels are shipped with the Midclamps. After the racking system is fully assembled, a single Marking Label should be applied to the rail at the edge of the array. Before applying the label, the corners of the label that do not pertain to the system being installed must be removed so that only the installed system type is showing. Note: The sticker label should be placed such that it is visible, but not outward facing.

Periodic Inspection

Conduct periodic inspections for loose components, loose fasteners or any corrosion, immediately replace any affected components.

UL 2703 Mechanical Load Test Ratings

Pro-Series Clamps

Downward Design Load (lb/ft ²)	113.4
Upward Design Load (lb/ft ²)	50.4
Down-Slope Design Load (lb/ft ²)	14.7

Legacy Top-Down Clamps

Downward Design Load (lb/ft ²)	112
Upward Design Load (lb/ft ²)	50
Down-Slope Design Load (lb/ft ²)	10